

HT51

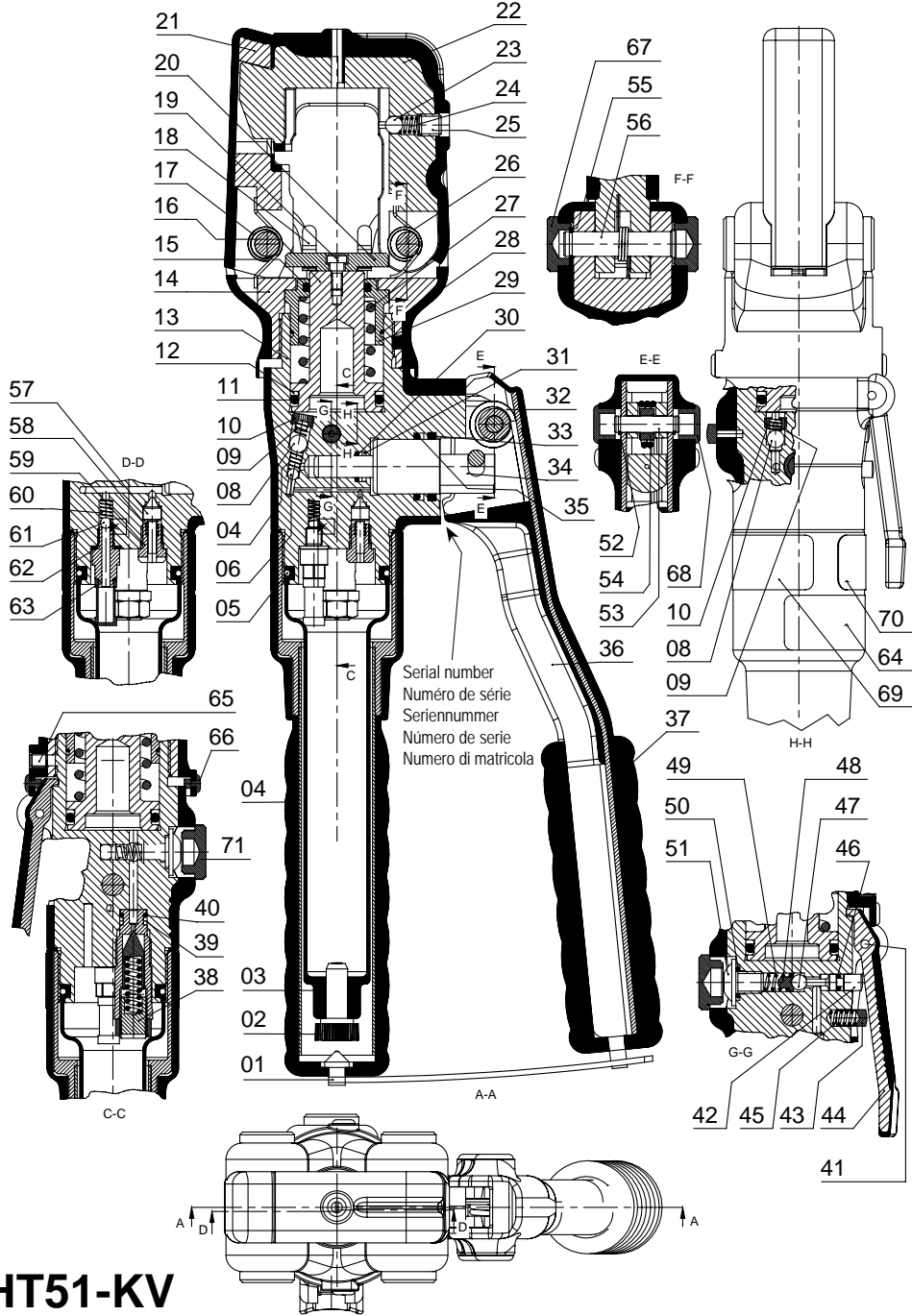

HT51-KV

PART LIST

Code N°	Item	DESCRIPTION	Qty
6090065	01	HANDLES RESTRAINT	1
6800040	02	RESERVOIR CAP	1
6720020	03	OIL RESERVOIR	1
○	04	MAIN HANDLE ASSY	1
6360250	★ 05	O-RING	1
6740100	★ 06	5/32" BALL	1
6520160	★ 07	SUCTION SPRING	1
6740020	★ 08	1/4" BALL	2
6520200	★ 09	SPRING	2
6340590	10	BALL POSITIONING DOWEL	2
6360300	★ 11	O-RING	1
6040240	★ 12	BACK-UP RING	1
○	13	BODY	1
○	▲ 14	HEAD SUPPORT	1
6362020	★ 15	SEAL	1
6620490	16	RAM	1
6520482	▲ 17	LATCH SPRING	1
6520382	18	DIE LOCKING SPRING	2
6900629	19	SCREW	1
6780252	20	DIE SUPPORT	1
○	▲ 21	LATCH	1
○	▲ 22	UPPER DIE HOLDER	1
6740020	▲ 23	1/4" BALL	1
6520942	▲ 24	SPRING	1
○	▲ 25	GRUB SCREW	1
6520403	▲ 26	DIE HOLDER OPENING SPRING	1
6520030	27	RAM SPRING	1
6361900	★ 28	ORM-RING	1
6040556	29	RAM GUIDING RING	1
6360161	★ 30	O-RING	1
6040101	★ 31	BACK-UP RING	1
6520401	32	HANDLE OPENING SPRING	1
6362020	★ 33	SEAL	1
6620090	34	PUMPING RAM	1
6360240	★ 35	O-RING	1
○	36	MOVEABLE HANDLE	1

Item	○ Code N°	
	HT51	HT51-KV
04	6480065	6480052
13	6160218	6170622
14	6780150	6780154
21	6370270	6370243
22	6780133	6780137
25	6340138	6340142
36	6480174	6480907
44	6440100	6440106

Code N°	Item	DESCRIPTION	Qty
6380200	37	MOVEABLE HANDLE GRIP	1
6895020	38	MAX PRESSURE VALVE	1
6040080	★ 39	BACK-UP RING	1
6360140	★ 40	O-RING	1
6760100	41	ø 3x16 SPRING PIN	1
6020027	42	PRESSURE RELEASE RAM	1
6600020	43	SPRING LOADED PIN	1
○	44	PRESSURE RELEASE LEVER	1
6520280	★ 45	SPRING	1
6360120	★ 46	O-RING	1
6740120	★ 47	7/32" BALL	1
6600100	48	BALL SUPPORT	1
6520520	★ 49	SPRING	1
6360166	★ 50	O-RING	1
6900341	51	M 8x10 SCREW	1
6700060	52	CIRCLIP	4
6560262	53	MOVEABLE HANDLE PIVOT	2
6080041	54	SPRING GUIDE BUSH	1
6040725	★▲ 55	CIRCLIP	2
6560370	▲ 56	HEAD PIVOT	2
6635011	57	PRESSURE RELEASE PIN	1
6520861	58	SPRING	1
6340720	59	PRESSURE RELEASE DOWEL	1
6520160	★ 60	SUCTION SPRING	1
6740100	★ 61	5/32" BALL	1
6641020	★ 62	M6 COPPER WASHER	1
6900601	63	SUCTION SCREW	1
6232018	64	(TG.0355) LABEL	1
6340038	65	M5x6 NYLON GRUB SCREW	1
6800089	66	PROTECTION CAP	2
6800086	67	PROTECTION CAP	4
6800088	68	PROTECTION CAP	4
6232178	69	(TG.0378) LABEL	1
6232271	70	(TG.0471) LABEL	1
6800099	71	PROTECTION CAP	1
6800012	▲	HT51 ASSEMBLED HEAD	
6860013	▲	HT51-KV ASSEMBLED HEAD	
6800071	★	SPARE PARTS PACKAGE	

The items marked (★) are those **Cembre** recommend replacing if the tool is disassembled.

These items are supplied on request in the "HT51/HT51-KV Spare Parts Package".

When ordering spare parts always specify the following:

- code number of item
- name of item
- type of tool
- serial number of tool

The guarantee is void if parts used are not Cembre original spares.