

DONATONI
Z1000
Z1200
Z1400
Z1600
Z2000

CNC MULTIFUNCTIONAL
WORK CENTRES



DONATONI
Stone Tech Creators

To highlight a machine and its potential often means to open the doors to new opportunities and markets





CONTENTS

05 ADVANTAGES

11 PROCESSING / APPLICATIONS

13 MAIN FEATURES

15 MAIN COMPONENTS

17 OPTIONALS

21 SOFTWARE

27 SERVICES AND AFTER-SALES SERVICE

29 TECHNICAL DATA

STRENGTH AND FLEXIBILITY WITHOUT COMPROMISE

CNC WORK CENTRE



GREAT FLEXIBILITY, GREAT PERFORMANCE

The **DONATONI Z1000-1200-1400-1600-2000** are large dimension CNC multifunctional work centres with **5/6 interpolated axis** with Z stroke from 1000 up to 2000 mm. These models are greatly used for working profiles and shapes of all types, straight, concave, convex, arches, drilling in 2 and 3 dimensional works, columns, sculptures and all types of cutting process. The **DONATONI Z** are work centres designed to be very versatile with high production capacities. Thanks to its steel briZe and increased dimensions, to all the movements of each axis given by brushless motors and high precision gearboxes running on linear bearings and gears on both X and Y axis in oil bath, it is possible to produce precise various types of forms, sizes and objects.

The machines work with an electro-spindle controlled by inverter with a TOOL M65 or ISO 50 connections which can hold disks from 500 mm diam to 1200 mm and diamond tools such as router bits and drill bits to perform a wide range of processing. The machines can be equipped with lathe and rotating platform controlled by CNC control, so bringing the axis controlled to 6. It is also possible to fit the machine as a bridge saw or as a complete CNC work centre thanks to the wide range of accessories available. The **DONATONI Z** are suited for the customer who wants to grow the company in order to open new doors and projects from an always demanding market of designers and architects.

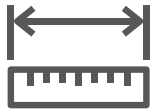

PRECISE FOR A PERFECT RESULT



EXTREMELY STRONG



FLEXIBLE AND REALIABLE



SHAPING AND DRILLING SPECIFIC



ABLE TO CUT THICK PIECES



EASY TO USE



WIDE RANGE OF ACCESSORIES



Q - QUADRIX: FOR SHAPING PROFESSIONALS

The DONATONI Z can be supplied with the Q-QUADRIX configuration. The Q configuration represents the synthesis of the best Donatoni technologies for the production of the best machines.



WHY YOU SHOULD CHOOSE Q-QUADRIX



Performance and efficiency

The Q version meets the highest efficiency and performance requirements for demanding machining operations, where the machine must be used for more than 8 hours a day, every day, for mass production or for the manufacturing of statues or design elements.

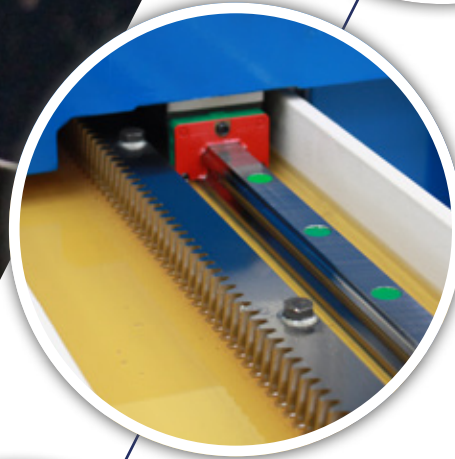

Oil-bath linear guides:

- Oil bath lubrication
- Less maintenance required
- Perfect sliding even under heavy and prolonged working conditions
- Maximum precision in the working phases



Quality in every single component

- Extremely precise and powerful brushless motors of the latest generation, with high efficiency.
- Reinforced steel structure for maximum machining precision

TECHNICAL CHARACTERISTICS



Available with bi-rotary head or with 0-90° rotation.



Large working range thanks to the Z axis, from 1000 to 2000 mm.



Maximum diameter of blades: 1100 or 1300 mm.

DONATONI Z RANGE TABLE

DONATONI Z 1000	DONATONI Z 1200	DONATONI Z 1400	DONATONI Z 1600	DONATONI Z 2000
Min./max. blade diameter: 500 - 1000 mm (opt. 1100 mm)	Min./max. blade diameter: 500 - 1000 mm (opt. 1100 mm)	Min./max. blade diameter: 500 - 1000 mm (opt. 1300 mm)	Min./max. blade diameter: 500-1000 mm (opt. 1300 mm)	Min./max. blade diameter: 500-1000 mm (opt. 1300 mm)
Z axis stroke: 1000 mm	Z axis stroke: 1200 mm	Z axis stroke: 1400 mm	Z axis stroke: 1600 mm	Z axis stroke: 2000 mm
Maximum cutting depth: 355 mm (455 mm)	Maximum cutting depth: 355 mm (455 mm)	Maximum cutting depth: 355 mm (500 mm)	Maximum cutting depth: 355 mm (500 mm)	Maximum cutting depth: 355 mm (500 mm)
X axis stroke: 4100 mm	X axis stroke: 4100 mm	X axis stroke: 4100 mm	X axis stroke: 4100 mm	X axis stroke: 4100 mm
X-Y axis sliding guides lubrication by means of an automatic greasing system	X-Y axis sliding guides lubrication by means of an automatic greasing system	X-Y axis sliding guides lubrication by means of an automatic greasing system	X-Y axis sliding guides lubrication by means of an automatic greasing system	X-Y axis sliding guides lubrication by means of an automatic greasing system

One range, many solutions

The DONATONI Z range consists of several models with a wide range of options and solutions that allow the machine to be customised according to customer needs.



Sliding guides with automatic grease lubrication or oil bath system.



Electrospindles from 28.5 kW up to 40 kW.

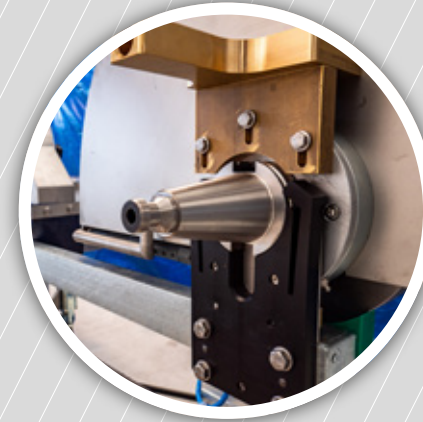

Tool connection M56 or ISO 50.

DONATONI Z-Q RANGE TABLE

DONATONI Z 1000 Q	DONATONI Z 1200 Q	DONATONI Z 1400 Q	DONATONI Z 1600 Q	DONATONI Z 2000 Q
Min./max. blade diameter: 500 - 1000 mm (opt. 1100 mm)	Min./max. blade diameter: 500 - 1000 mm (opt. 1100 mm)	Min./max. blade diameter: 500-1000 mm (opt. 1300 mm)	Min./max. blade diameter: 500-1000 mm (opt. 1300 mm)	Min./max. blade diameter: 500-1000 mm (opt. 1300 mm)
Z axis stroke: 1000 mm	Z axis stroke: 1200 mm	Z axis stroke: 1400 mm	Z axis stroke: 1600 mm	Z axis stroke: 2000 mm
Maximum cutting depth: 355 mm (455 mm)	Maximum cutting depth: 355 mm (455 mm)	Maximum cutting depth: 355 mm (500 mm)	Maximum cutting depth: 355 mm (500 mm)	Maximum cutting depth: 355 mm (500 mm)
X axis stroke: 3800 mm	X axis stroke: 3800 mm	X axis stroke: 4600 mm	X axis stroke: 4600 mm	X axis stroke: 4600 mm
X-Y axis sliding guides lubrication in oil bath	X-Y axis sliding guides lubrication in oil bath	X-Y axis sliding guides lubrication in oil bath	X-Y axis sliding guides lubrication in oil bath	X-Y axis sliding guides lubrication in oil bath

TECHNOLOGY AT THE SERVICE OF DESIGN AND ART

EFFICIENCY AND
FLEXIBILITY



PROCESSING

Columns, sculptures, bath tubs, wash basins, shower plates, panels for internal and external cladding, steps, window dressings, building material, monuments and head stones.

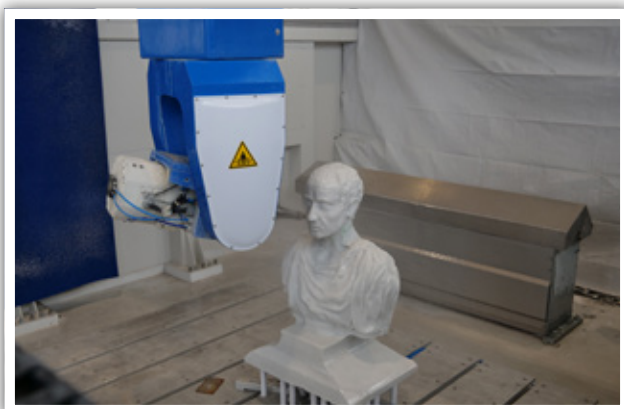

THE SOLUTION FOR GREAT CHALLENGES

MAIN FEATURES



TYPE OF PROCESSING



SHAPES



DRILLING



STATUES



CUTTING

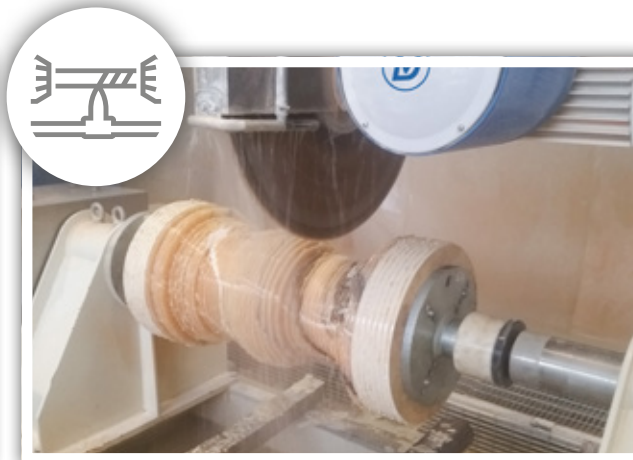

LATHE



MILLING

INNOVATION IS STANDARD

MAIN COMPONENTS



Electro-spindle of very high quality, with twin rotating head installed on steel carriage controlled by inverter allowing to vary the speed of the blade or tool from 0 to 5000/6000/8000 rpm. Provided with Bi-rotary head – Tool with continuous inclination from -20 to 200 degrees, very useful with 5 axis work with blade or router tool. It is possible to use blades, drilling and router bits. The tools can be changed either manually or automatically.



AIR COOLING SYSTEM



LIQUID COOLING SYSTEM

Sliding cross-beams with linear bearings and helicoidal-teeth racks for the X and Y axis, with automatic grease or oil bath lubrication and bellows and bellows for protection with labyrinth closure.

Bridge: designed to assure the best support to the sleeve and the electro-spindle and to guarantee maximum precision. The structure is in zinc-plated normalized steel, sandblasted and painted with 3 coats of paint.



ACCESSORIES AND MECHANICAL COMPONENTS

OPTIONALS



Working bench and platform: available in different models, sizes and surfaces, with top in wood, steel, aluminum, with overbench, based on the selected accessories and on customer needs.

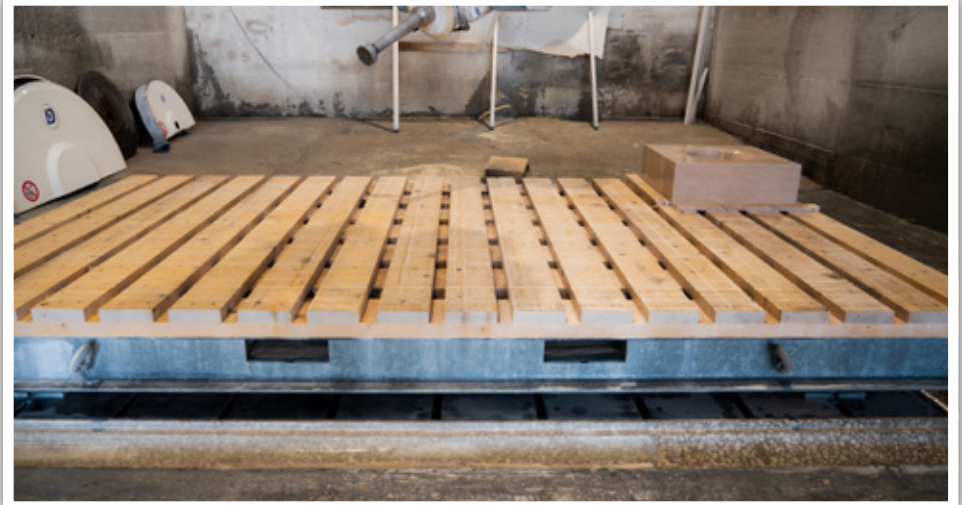
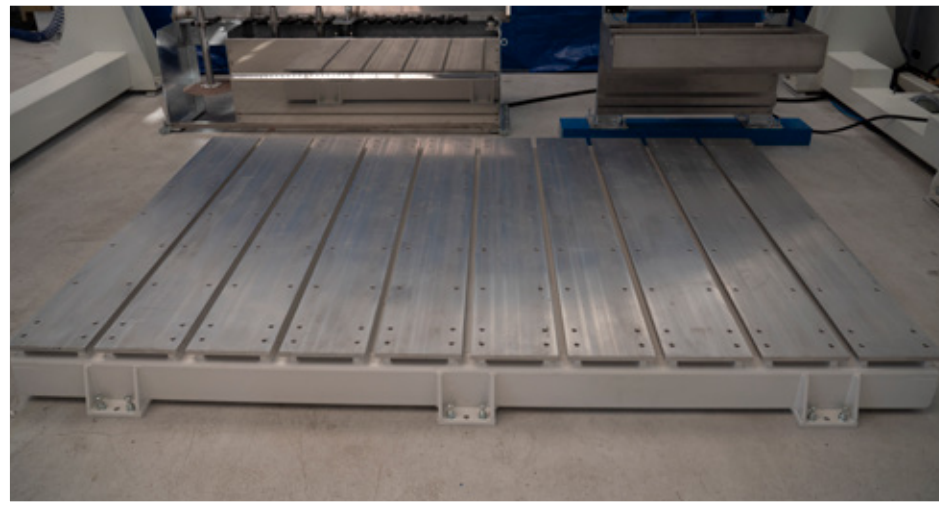

Slab thickness detector: automatic detection system of slab thickness.



3d scanner ARTEC: is a professional instrument to scan objects of various sizes such as statues, capitals for columns, objects of high design and any special shapes and forms of various dimensions in various formats.

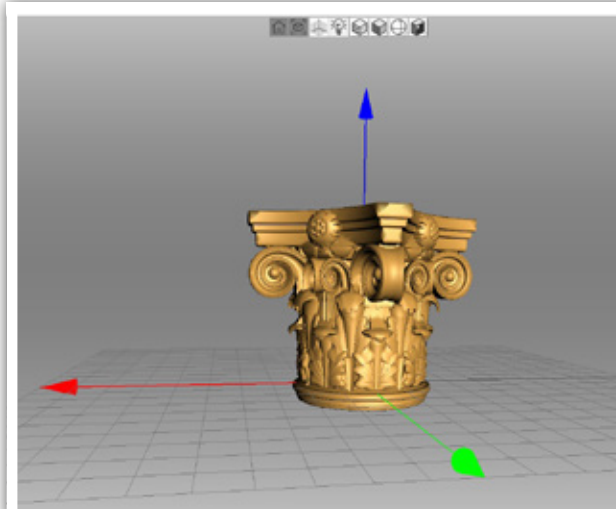

Camera for slab: Slab detection system, with camera placed above the workbench and image acquisition software. The application allows to speed up the machine programming, to position each piece and detect any slab defects.

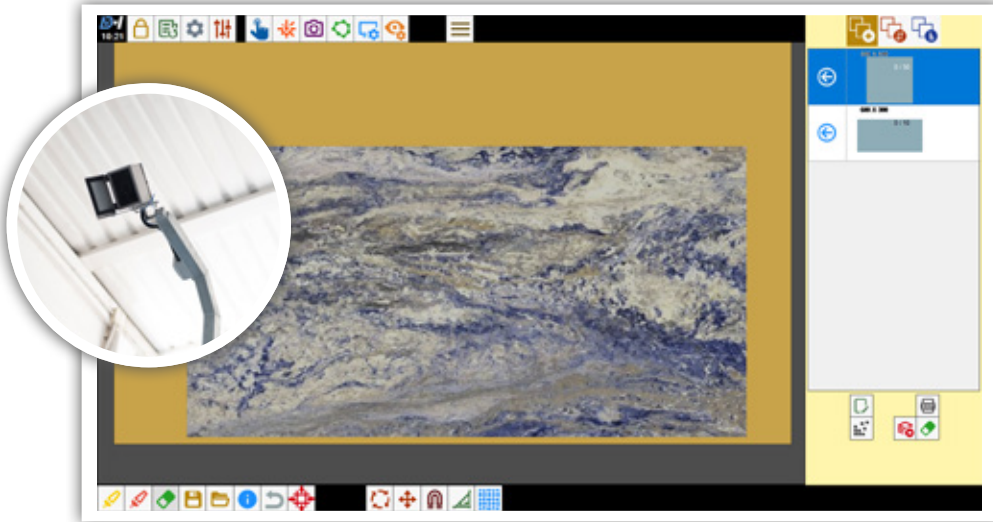

Linear tool storage at 10 positions for ISO 50 cones with max. length 600 mm, complete with pneumatic- lifting stainless steel cover.



Rotary tool storage at 16 positions for ISO 50 cones and two positions for vertical blade diam. 625 and 825 mm. The tool holder is placed alongside the machine and moves through a mobile base allowing to be placed within the working area to change the tool/blade.



Tool presetting: tool thickness detector, essential for precise processing.



Lathe: interpolated lathe to produce columns of different sizes and complex forms



Blade change: available in 2 versions (single or double), for 625 or 825 mm blades.

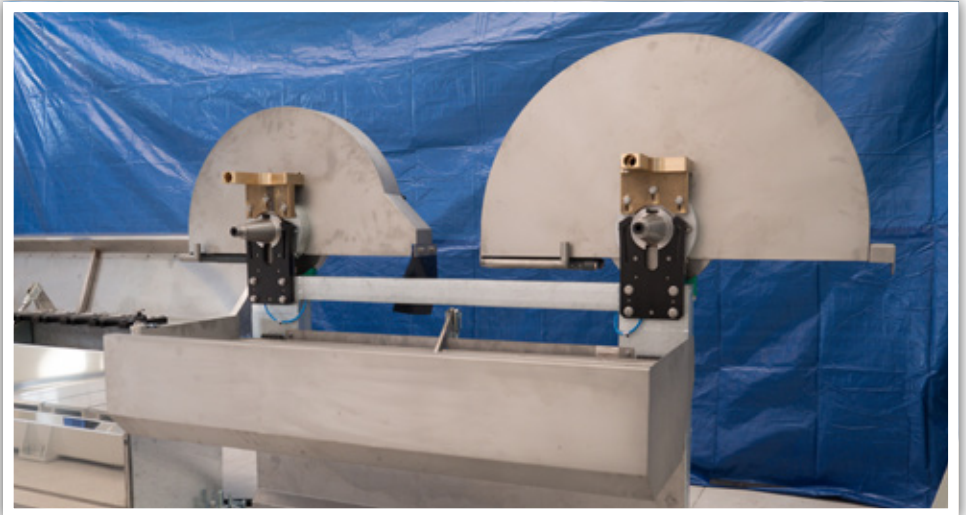

Suction Cups Kit: system for fixing the pieces by means of suction cups and vacuum pump (to be combined with fixed or tilting aluminum bench or platform).

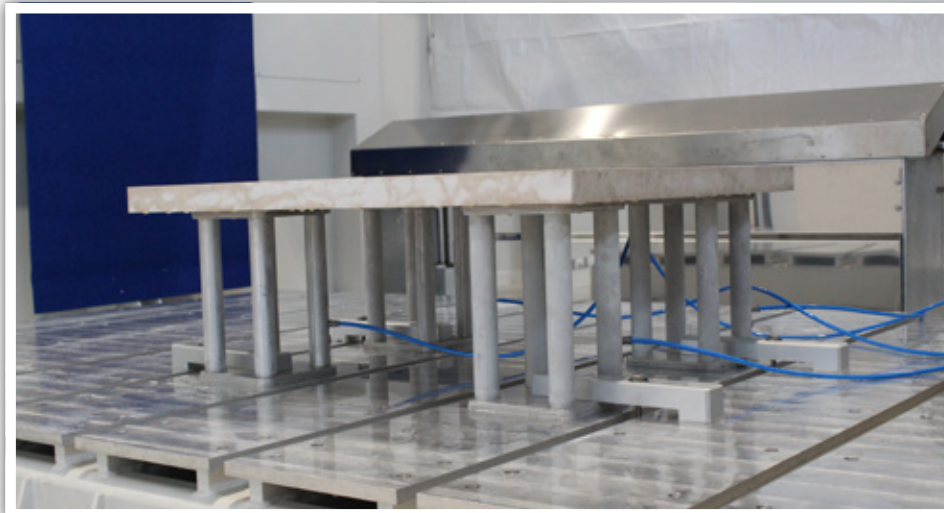

Steel walls: sandblasted and painted with 3 coats of paint.



AN INTELLIGENT SYSTEM TO MAKE YOUR WORK EASIER

LET US GUIDE YOU TOWARDS
THE FUTURE OF INTELLIGENT
MACHINES



D-INSIDE:

EQUIP YOURSELVES WITH
A SUPERIOR FORM OF INTELLIGENCE



OPERATOR
INTERFACE WITH
PC AND 21" TOUCH
SCREEN MONITOR

HIGH PERFORMANCE
THANKS TO THE
NEW POWERFUL PC

USB
PORTS FOR
TRANSFERRING
FILES

CONTROLS FOR
THE MANUAL
MOVEMENTS
OF EACH AXIS

MOBILE, STIFF ARM
THAT ALLOWS
THE OPERATOR TO
PROGRAM WITH 1
HAND



Perfect machining can only be achieved through multiple movements that need to be perfect coordinated. Just as all the movements in the human body are managed through brain impulses, similarly, the movements of our machines are managed by **integrating the machine with the programming software.**

Every Donatoni machine is born with an intelligent work management system, integrated with all the parts that manage its movements; we call this system **D-Inside**, the real brain of the machine. It is an advanced interface that is simple to use, even for inexperienced operators, which allows the machine-software system to be coordinated.

The D-Inside system offers many programming options and can be interfaced with the different types of Donatoni software, such as Parametrix and all the additional modules, or with CAD-CAM DDX EasySTONE, so as to customise the machine to meet the customer's requirements.

PARAMETRIX

Parametrix is the **simple and user-friendly Software** developed by Donatoni Macchine that was conceived to optimise cutting different shaped pieces from slabs.

It is a software which **allows you to manage cutting processes using a blade, it allows the user to input both rectilinear and curvilinear shapes** (steps, kitchen worktops, rectangles, covers) using pre-defined shapes in the program or shapes imported from DXF files.

Depending on the surface available, it is possible to set the position of the pieces and the sequence of the cuts, optimising the times and reducing the material waste.

The software includes the following functions: **for preventing the collision of pieces, manual and automatic piece nesting, managing production and order statistics.**

Parametrix can be used together with Photoslab and Move-System, which allow the slab to be detected automatically and the cut pieces to be moved using a suction cup system, thereby **reducing operator intervention to a minimum.**

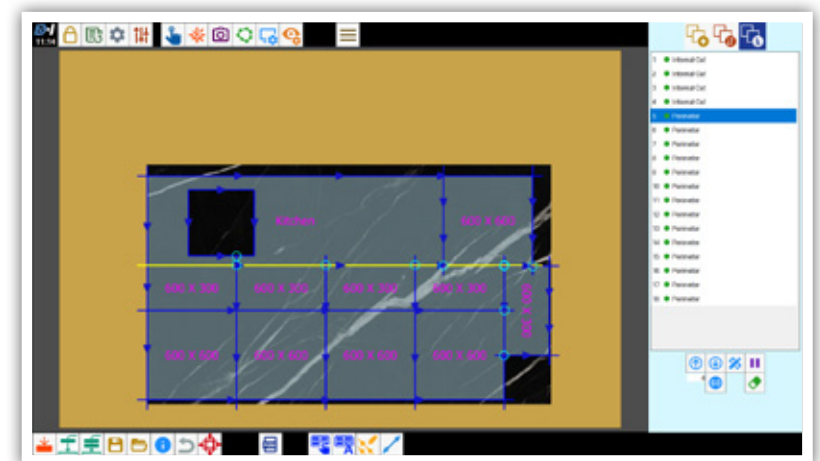

Automatic nesting

Automatically inserts the square or rectangular pieces into the work area, optimizing the use of the slab.

Drilling and processing with the milling cutter

It allows you to manage the use of tools, drills and milling cutters, with which it is possible to cut pieces or parts of the slab, to complete the initial work process with the blade.

Positioning of the pieces on the slab

With the manual nesting function, it is possible to preview any collisions between the parts, thereby making it easier to position the pieces in the best possible way.

Managing and changing of cuts

After having positioned the pieces, the cuts can be modified: it is possible to lengthen them, to change their order, to disable them, to add pauses, as well as other types of modifications, before pressing the start button to start the cutting phase.

Bookmatching (optional)

Allows the user to see the aesthetic result obtained by combining the pieces and to fully evaluate the "bookmatching"-type process.

DM_TL (optional)

Program for honing / polishing / brushing slabs by means of the plate carrying Frankfurt abrasives.

Photoslab (optional)

By means of a camera placed above the machine and the related record software, the slab being cut is automatically detected. The system allows the optimization and the exploitation of the slab dimensions, the speeding of pieces positioning, avoiding possible defects or enabling to perform cuts by following the veins of the material. The software is automatically enabled with installation of "camera for slabs".

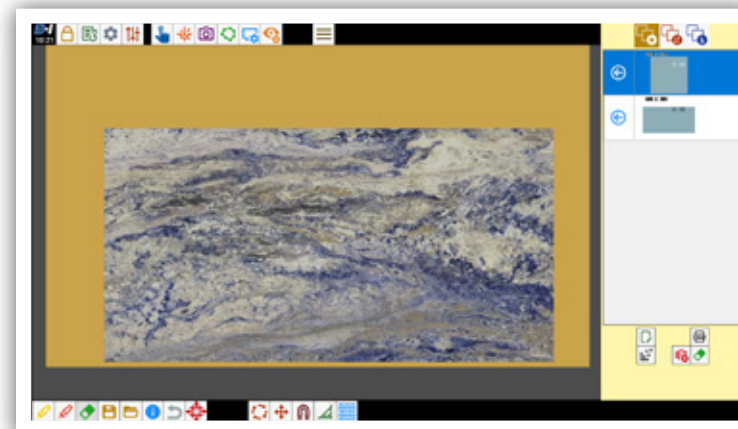
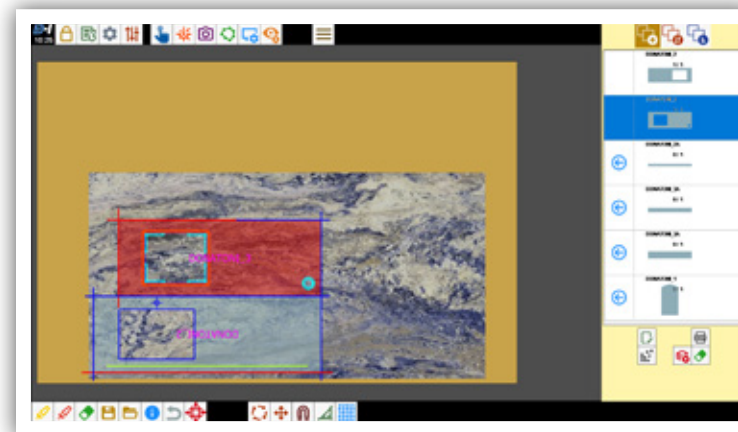

CAD-CAM

OPTIONAL

The software allows to design, import and execute 2D and 3D files in DXF, IGES, STL, PNT, STEP and RHINO formats and to define surfaces and shapes through laser scanning. Multiple processes can be set: roughing, drilling, profiling, emptying and polishing, which can be carried out by optimizing the execution process.

After the import, the software optimizes processing paths, performs roughing / finishing taking into account the raw material resulting after processing.

With CAD-CAM it is possible to display the processing 3D image with virtual milling and to modify it if required. The 3D simulation of the processing, including free displacements, is realistic as it is based on the Customer's machine model and shows the three-dimensional model of the working center, of the bench, of the motors, the tools, the sub-pieces and the pieces .

Once the design phase is completed, CAD-CAM generates the piece-programs and sends it directly to the Customer's working center. Finally, it calculates times, lengths and processing costs, allowing accurate reporting of the work performed.

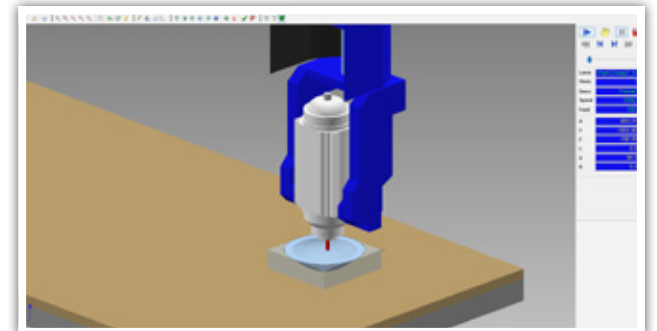
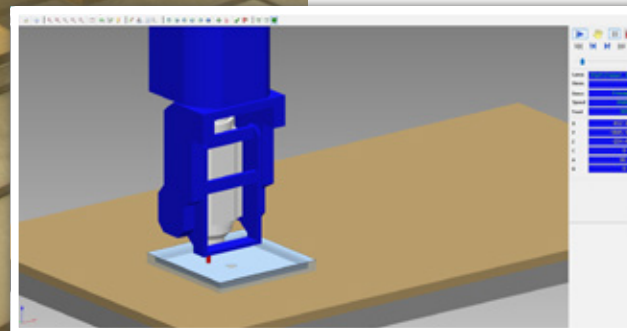
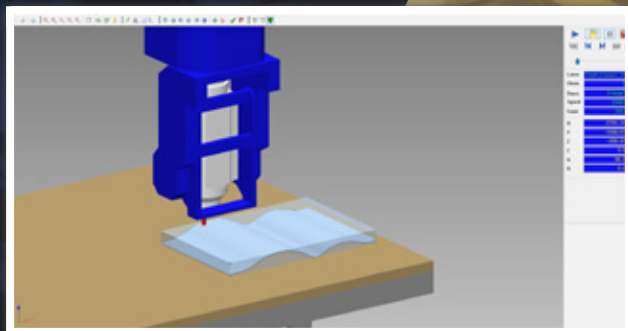

Drawing: the software provides drawing tools allowing to easily create 2D shapes and even complex 3D surfaces. It is also possible to import surfaces produced with other modeling software or coming from the scanning of real objects.

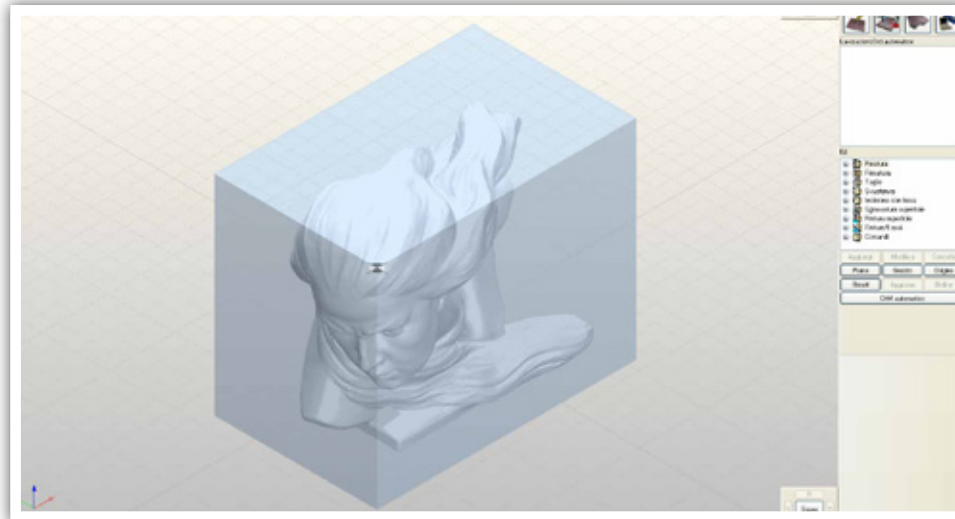

Tool storage management: the software manage tool magazine and creates working kits. This allows to create a database by type of processing, containing all the necessary tool parameters already set, saving time for programming.

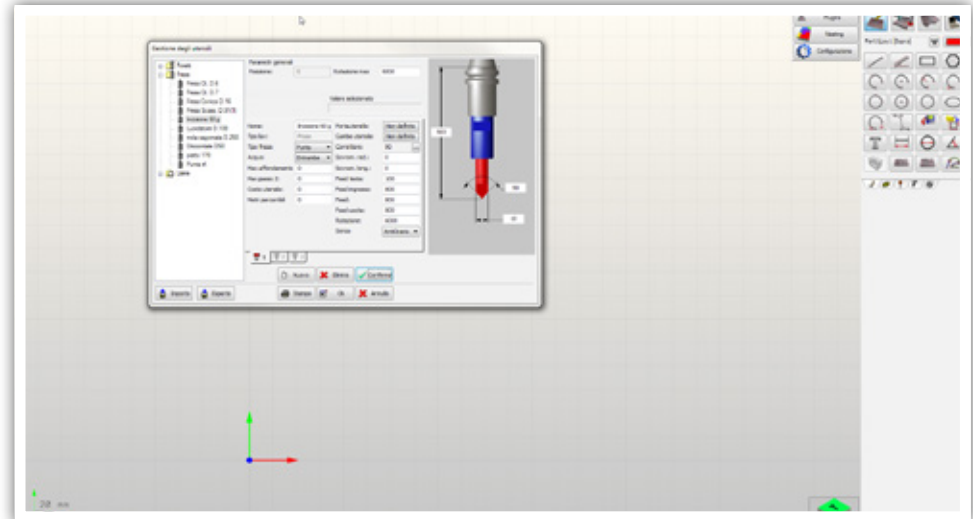

Working management: the project that has to be realized out often requires the use different processes (finishing, roughing ...), which have to be carried out using different tools. The application of these processes is done directly on 3D model and the operator immediately has feedback on the tool paths and uptake so allowing you to deal with the process in the most congenial way.

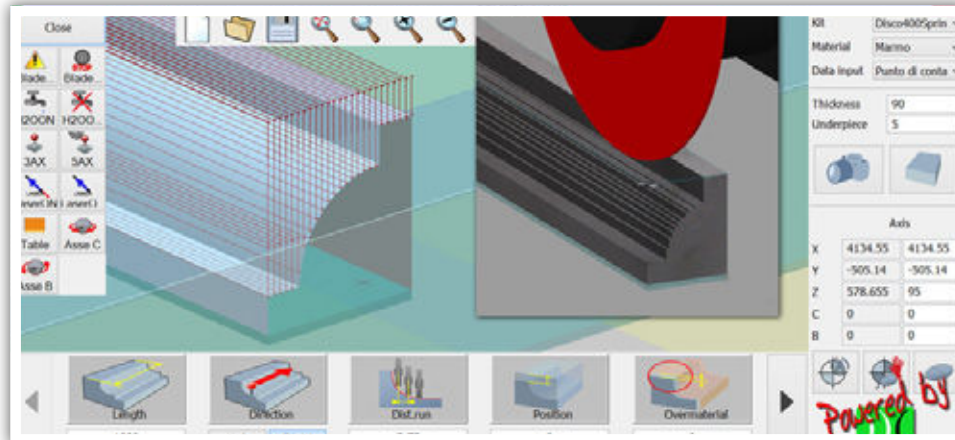

Simulation: the program allows to simulate the operations that will be actually performed by providing a model of the machine, tools and the material processed. In the simulator, during the movement of the tool on the material, it will be possible to display the actual material removal and to have a preview vision of the final result.

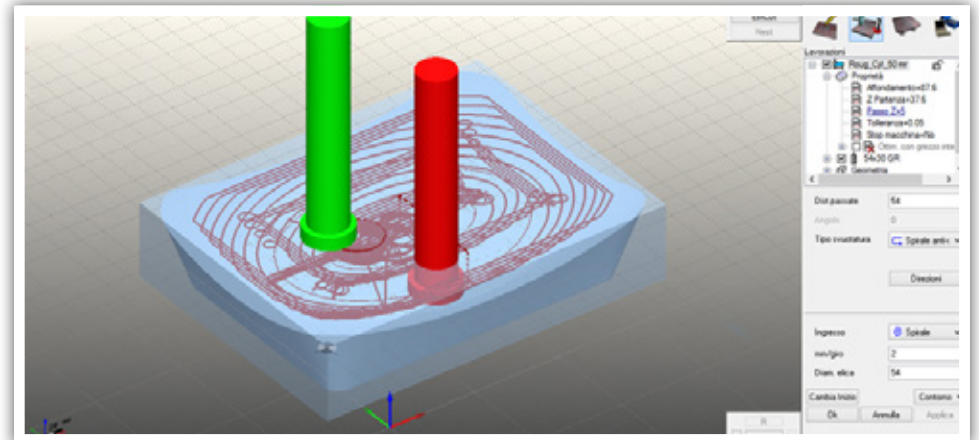

WITH DONATONI YOU ARE NEVER ALONE

SERVICES AND
AFTER-SALES SERVICE

The relationship with our Customer does not end with the supply of the product, but continues and is strengthened through a reciprocal collaboration, which is of value for both our Customer and us



DIRECTLY CONNECTED WITH OUR TECHNICIANS

WORLDWIDE SALES AND ASSISTANCE STRUCTURE

Donatoni is present in many countries worldwide thanks to a structure of reliable and competent partners and agents, among which the Intermac branches of the Biesse group.

MACHINE INSTALLATION

Our machines are installed by highly specialised technicians with long-standing experience, thanks to whom we can guarantee a high level of service. The installation not only includes the careful installation of the machine, but also its commissioning and the training of operators, according to the machine model that has been installed.

ON-SITE ASSISTANCE

We provide on-site technical assistance at the customer's premises if it is not possible to use Remote Assistance.

Donatoni Service is the company department that is totally dedicated to our customers and their needs; it provides a wide range of **services aimed to meet all of our customers' requirements**, before, during and after the delivery and installation of the machine and throughout its life cycle. Our highly qualified personnel have long-standing experience and are capable of responding to any question or request.

We use an open approach that pays careful attention to specific individual needs, because our objective

DIRECTLY CONNECTED - ON-LINE ASSISTANCE

Each machine is supplied with a system that enables it to be connected by remote assistance to our after-sales service (this requires a connection to the network via cable). This service enables our technical staff to virtually access the customer's machine and to carry out checks and updates, but also to provide technical assistance just as if they were right there at the machine's location.

PARTS AND REPLACEMENTS SERVICE

We handle requests for parts and replacements in any part of the world, promptly in order to minimise machine downtimes.

CAD-CAM TECHNICAL ADVICE

We help our customers with the creation and design of complex projects and objects using their machines.

is to cooperate with and support our customers in their production activities, not only by offering them assistance but also by offering them **technical services and advice**, which allow the operators to improve their know-how and enhance their production. Speed, reliability and professionalism are the strengths that allow us to guarantee an efficient response to your requests; our Service uses state-of-the-art communication tools and a **global network of partners** so as to provide prompt answers and solutions.

THEORETICAL/PRACTICAL TRAINING

Training courses and update courses regarding new applications and software are carried out at our offices or at our customers' premises. Our offices are equipped to host courses for technicians and operators. The rooms are next to the machines on display in our show room and, therefore, this allows tests and checks to be carried out directly on the console of the machine as well as the evaluation of the level of learning achieved by the participants.



LAY-OUT DONATONI Z1000 / 1200 / 1400 / 1600 / 2000

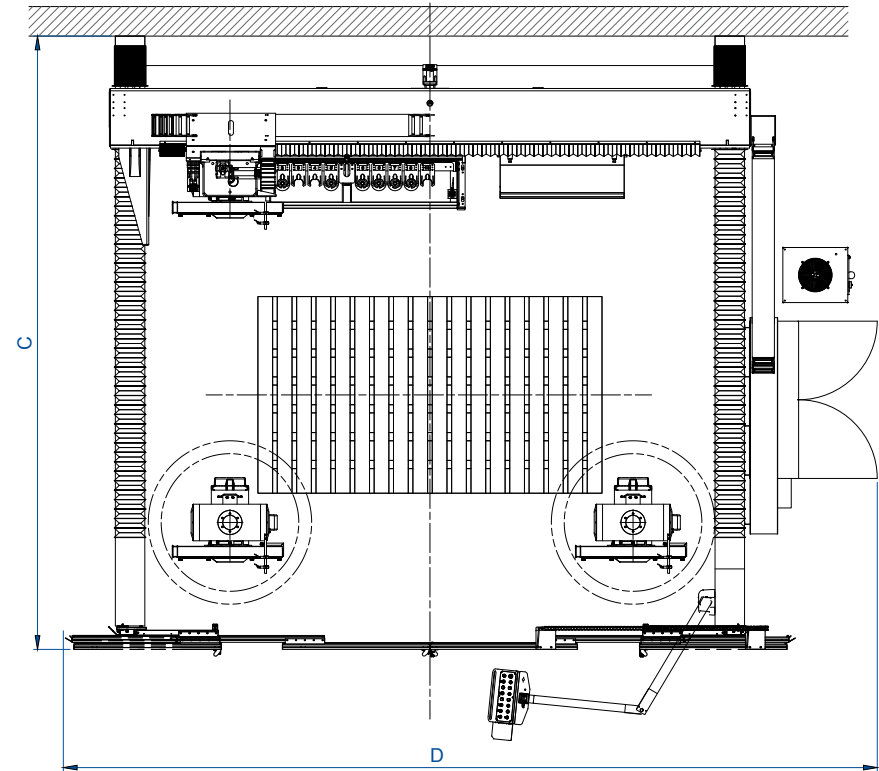
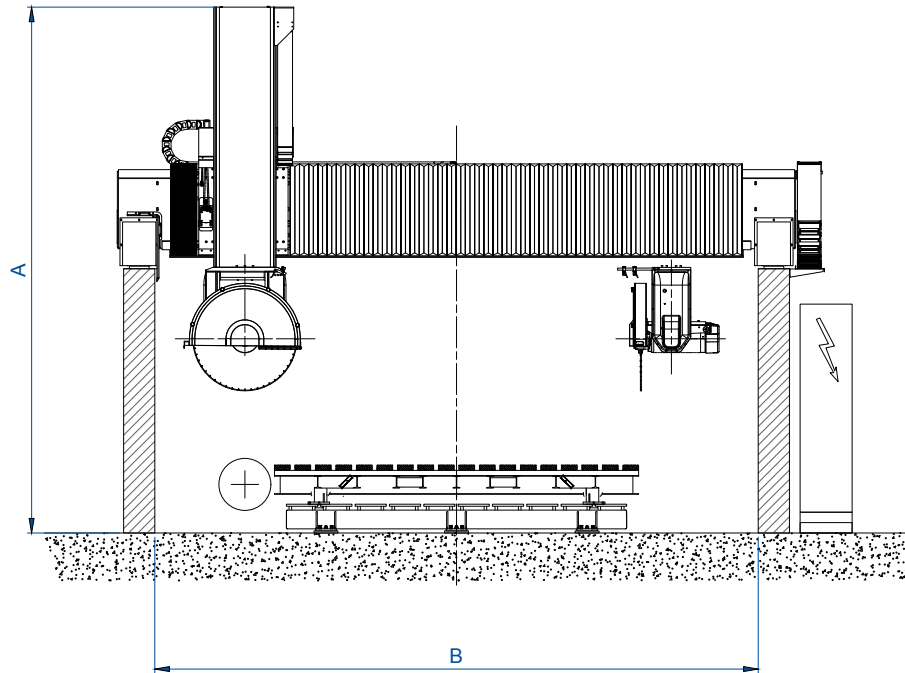

A:
Z1000: 4750 MM
Z1200: 4950 MM
Z1400: 5100 MM
Z1600: 5450 MM
Z2000: 6300 MM

B:
Z1000: 5330 MM
Z1200: 5330 MM
Z1400: 5800 MM
Z1600: 5800 MM
Z2000: 5800 MM

C:
Z1000: 5550 MM
Z1200: 5550 MM
Z1400: 6250 MM
Z1600: 6250 MM
Z2000: 6250 MM

D:
Z1000: 7850 MM
Z1200: 7850 MM
Z1400: 8250 MM
Z1600: 8250 MM
Z2000: 8250 MM

TECHNICAL DATA

DONATONI Z1000 / 1200 / 1400 / 1600 / 2000

		1000	1200	1400	1600	2000
Max number of interpolated axes	N°	5 / 6	5 / 6	5 / 6	5 / 6	5 / 6
Carriage stroke axis X	mm	4100	4100	4100	4100	4100
	in	161,4	161,4	161,4	161,4	161,4
BriZe stroke axis Y	mm	4300	4300	3500	3500	3500
	in	169,3	169,3	138,7	137,8	137,8
Vertical stroke of the head axis Z	mm	1000	1200	1400	1600	2000
	in	39,3	47,2	51,1	62,9	78,7
Disk head rotation (axis C)	gradi	-5° / +545°	-5° / +545°	-5° / +545°	-5° / +545°	-5° / +545°
Disk head tilting movement (axis A)	gradi	0 - +90° (-20 / +200° opt.)	0 - +90° (-20 / +200° opt.)	0 - +90° (-20 / +200° opt.)	0 - +90° (-20 / +200° opt.)	0 - +90° (-20 / +200° opt.)
Working table dimensions	mm	2000 x 3500	2000 x 3500	2000 x 3500	2000 x 3500	2000 x 3500
	in	78,7 x 137,7	78,7 x 137,7	78,7 x 137,7	78,7 x 137,7	78,7 x 137,7
Minimum disk diameter	mm	500	500	500	500	500
	in	19,6	19,6	19,6	19,6	19,6
Max disk diameter	mm	1000 (opt. 1300)	1000 (opt. 1300)	1000 (1300 opt.)	1000 (1300 opt.)	1000 (1300 opt.)
	in	39,3 (opt. 43,3)	39,3 (opt. 43,3)	39,3 (51,1 opt.)	39,3 (51,1 opt.)	39,3 (51,1 opt.)
Max cutting depth	mm	360 (opt. 500)	360 (opt. 500)	360 (500 opt.)	360 (500 opt.)	360 (500 opt.)
	in	14,1 (opt. 19,7)	14,1 (opt. 19,7)	14,1 (19,7 opt.)	14,1 (19,7 opt.)	14,1 (19,7 opt.)
Electro-spindle motor power	kW	29,5 kW (40 kW opt.)	29,5 kW (40 kW opt.)	29,5 kW (40 kW opt.)	29,5 kW (40 kW opt.)	29,5 kW (40 kW opt.)
Tools rotation with inverter	Rpm	0- 5000 (8000 opt.)	0- 5000 (8000 opt.)	0- 5000 (8000 opt.)	0- 5000 (8000 opt.)	0- 5000 (8000 opt.)
Tool connection cone	ISO	M56 (ISO-50 opt.)	M56 (ISO-50 opt.)	M56 (ISO-50 opt.)	M56 (ISO-50 opt.)	M56 (ISO-50 opt.)
Speed axis X	m / min	0 - 37	0 - 37	0 - 37	0 - 37	0 - 37
	ft / min	0 - 121,4	0 - 121,4	0 - 121,4	0 - 121,4	0 - 121,4
Speed axis Y	m / min	0 - 37	0 - 37	0 - 37	0 - 37	0 - 37
	ft / min	0 - 121,4	0 - 121,4	0 - 121,4	0 - 121,4	0 - 121,4
Speed axis Z	m / min	0 - 9	0 - 9	0 - 12	0 - 12	0 - 12
	ft / min	0 - 29	0 - 29	0 - 39	0 - 39	0 - 39
Speed of axes X Y	m / min	0 - 37	0 - 37	0 - 37	0 - 37	0 - 37
	ft / min	0 - 121,4	0 - 121,4	0 - 121,4	0 - 121,4	0 - 121,4
Water consumption	l / min	50	50	50	50	50
	gal / min	13,2	13,2	13,2	13,2	13,2
Air consumption	l / min	20	20	20	20	20
	gal / min	5,2	5,2	5,2	5,2	5,2
Standard voltage	Volt / Hz	400 / 50	400 / 50	400 / 50	400 / 50	400 / 50
Total weight standard machine	kg	4700	4750	5950	6000	6100
	lb	10361,73	10471,96	13117,5	13227,74	13448,2

The technical data and images in this catalog are indicative and do not constitute a constraint. The manufacturer reserves the right to make changes to the product, technical data and images without prior notice.

LAY-OUT DONATONI Z1000 Q / 1200 Q / Z1400 Q / 1600 Q / 2000 Q

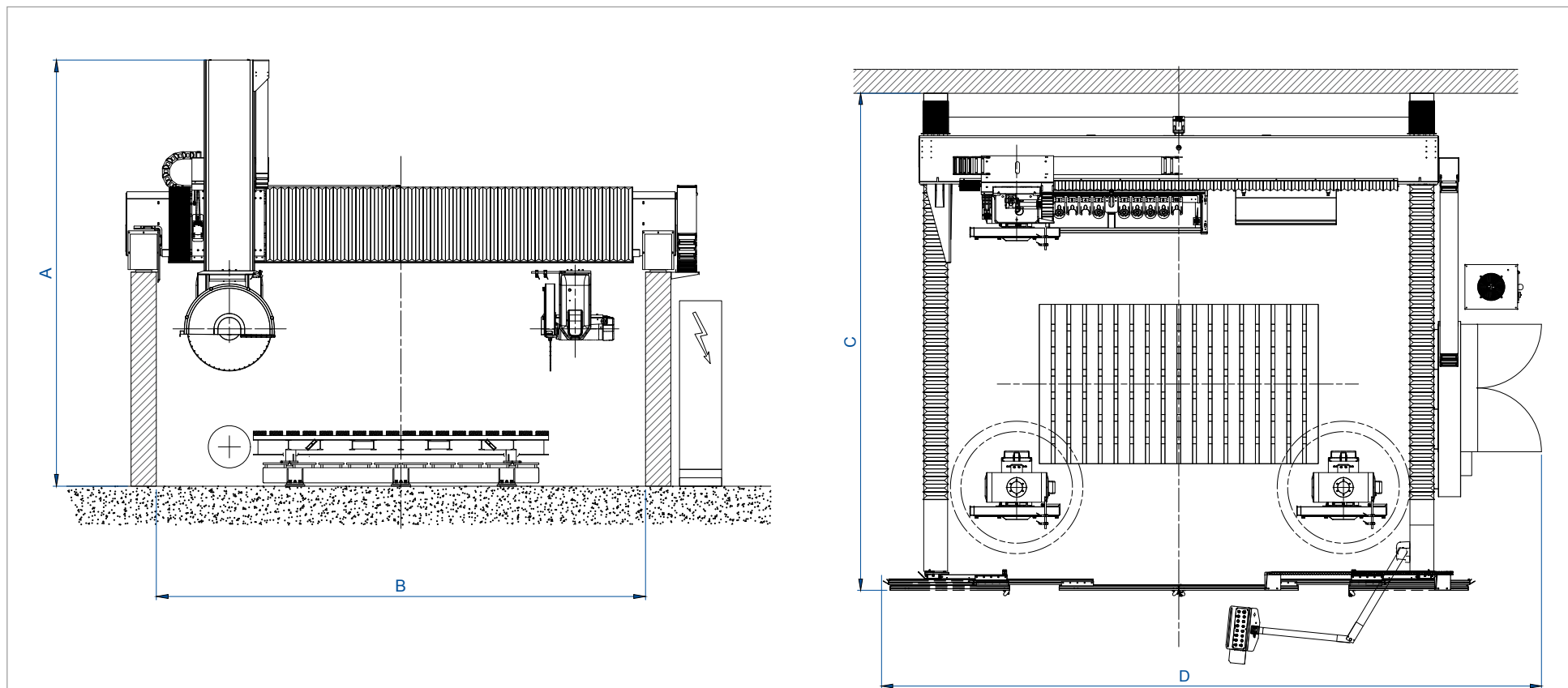

A:
Z1000: 4600 MM
Z1200: 4700 MM
Z1400: 5950 MM
Z1600: 6150 MM
Z2000: 6450 MM

B:
Z1000: 5750 MM
Z1200: 5750 MM
Z1400: 6100 MM
Z1600: 6100 MM
Z2000: 6100 MM

C:
Z1000: 6700 MM
Z1200: 6700 MM
Z1400: 6800 MM
Z1600: 6800 MM
Z2000: 6800 MM

D:
Z1000: 7800 MM
Z1200: 7800 MM
Z1400: 8400 MM
Z1600: 8400 MM
Z2000: 8400 MM

TECHNICAL DATA

DONATONI Z1000 Q / 1200 Q / Z1400 Q / 1600 Q / 2000 Q

		1000	1200	1400	1600	2000
Max number of interpolated axes	N°	5 / 6	5 / 6	5 / 6	5 / 6	5 / 6
Carriage stroke axis X	mm	3800	3800	4600	4600	4600
	in	149,6	149,6	181,1	181,1	181,1
BriZe stroke axis Y	mm	3000	3000	3500	3500	3500
	in	118,1	118,1	137,8	137,8	137,8
Vertical stroke of the head axis Z	mm	1000	1200	1400	1600	2000
	in	39,3	47,2	51,1	62,9	78,7
Disk head rotation (axis C)	gradi	-5° / +545°	-5° / +545°	-5° / +545°	-5° / +545°	-5° / +545°
Disk head tilting movement (axis A)	gradi	-20° / +200°	-20° / +200°	-20° / +200°	-20° / +200°	-20° / +200°
Working table dimensions	mm	2000 x 3500	2000 x 3500	2000 x 3500	2000 x 3500	2000 x 3500
	in	78,7 x 137,7	78,7 x 137,7	78,7 x 137,7	78,7 x 137,7	78,7 x 137,7
Minimum disk diameter	mm	500	500	500	500	500
	in	19,6	19,6	19,6	19,6	19,6
Max disk diameter	mm	1000 (opt. 1300)	1000 (opt. 1300)	1000 (1300 opt.)	1000 (1300 opt.)	1000 (1300 opt.)
	in	39,3 (51,1 opt.)	39,3 (51,1 opt.)	39,3 (51,1 opt.)	39,3 (51,1 opt.)	39,3 (51,1 opt.)
Max cutting depth	mm	360 (500 opt.)	360 (500 opt.)	360 (500 opt.)	360 (500 opt.)	360 (500 opt.)
	in	14,1 (19,7 opt.)	14,1 (19,7 opt.)	14,1 (19,7 opt.)	14,1 (19,7 opt.)	14,1 (19,7 opt.)
Electro-spindle motor power	kW	40 / 56	40 / 56	40 / 56	40 / 56	40 / 56
Tools rotation with inverter	Rpm	0 - 8000	0 - 8000	0 - 8000	0 - 8000	0 - 8000
Tool connection cone	ISO	50	50	50	50	50
Speed axis X	m / min	0 - 40	0 - 40	0 - 40	0 - 40	0 - 40
	ft / min	0 - 131,2	0 - 131,2	0 - 131,2	0 - 131,2	0 - 131,2
Speed axis Y	m / min	0 - 40	0 - 40	0 - 40	0 - 40	0 - 40
	ft / min	0 - 131,2	0 - 131,2	0 - 131,2	0 - 131,2	0 - 131,2
Speed axis Z	m / min	0 - 13	0 - 13	0 - 15	0 - 15	0 - 15
	ft / min	0 - 42,6	0 - 42,6	0 - 49,2	0 - 49,2	0 - 49,2
Speed of axes X Y	m / min	0 - 40	0 - 40	0 - 40	0 - 40	0 - 40
	ft / min	0 - 131,2	0 - 131,2	0 - 131,2	0 - 131,2	0 - 131,2
Water consumption	l / min	50	50	50	50	50
	gal / min	13,2	13,2	13,2	13,2	13,2
Air consumption	l / min	20	20	20	20	20
	gal / min	5,2	5,2	5,2	5,2	5,2
Standard voltage	Volt / Hz	400 / 50	400 / 50	400 / 50	400 / 50	400 / 50
Total weight standard machine	kg	5000	5050	7800	7850	8000
	lb	11023,11	11133,34	17196,06	17306,29	17636,98

The technical data and images in this catalog are indicative and do not constitute a constraint. The manufacturer reserves the right to make changes to the product, technical data and images without prior notice.

Member of:



CONFINDUSTRIA MARMOMACCHINE
ASSOMARMOMACCHINE

Donatoni Macchine Srl

Via Napoleone 14, 37015 Domegliara - Sant'Ambrogio di Valpolicella / Italy

Tel. +39 045 6862548

Fax +39 045 688 43 47

info@donatonimacchine.eu

www.donatonimacchine.eu

www.donatonimacchine.eu

Donatoni Macchine, founded by Vittorio Donatoni in 1959 in Domegliara, one of the main marble and granite processing districts, is recognised, thanks to their years of experience gained in the natural stone industry during this time, as one of the world leaders in manufacturing **cutting-edge machines of very high quality for working stone.**

Constant research, technological innovation and customer service are key concepts for the company and in order to pursue them the company employs highly qualified technical and commercial personnel, in order to guarantee the end customer a **product that reflects their expectations in terms of quality and performance.**

Diamente.it

DONATONI
Stone Tech Creators